



C/- P.O. Rhyll, Victoria, 3923.

VICTORIAN RAILWAYS 'T' VAN

Prototype Notes

The "T" van was designed for the carriage of perishable goods requiring refrigeration in summer, although other classes of goods could be carried under certain conditions. The wagon was cooled with ice and heavily insulated to remain cold for several days.

The model is based upon the 15 ton wooden version introduced in 1909. Originally built with 6 wheels, these wagons were rebuilt in the 1930's with 4 wheels. Some wagons were fitted with two end bunkers instead of the standard arrangement with three hatches. Five wagons were rebuilt in the late 1950's and early 1960's with high speed bogies for use on passenger trains. Coded TP these wagons were used mainly on the Mildura line.

The wagons represented by this kit were numbered in the range 192-343 and 392-417. Wagons with end bunkers and only two roof hatches were numbered 343-392. The April 1995 issue of the Australian Model Railway Magazine features an article on the V.R. T vans which provides further information on their history.



Model illustrated has been fitted with shunter's steps, handbrake and couplers (not included).

Assembly

It is recommended that this kit be assembled with a liquid solvent such as Microscale Microweld.

Like all plastic kits the final result depends on the care taken in assembly. If all parts are dry fitted in position and filed or sanded as necessary to achieve a good fit, before glueing in place, the final result will be a much better model.

The plastic used in this kit may be attacked by some oils, therefore axles should only be lubricated with powdered graphite or Teflon lubricant.

Read all instructions before commencing assembly. Remove all parts from sprues using a knife or razor saw. Clean up all parts with a flat file. Remove the moulding pips from the back of the axleboxes but DO NOT remove locating lugs from back of wagon ends.

Remove the draft or slight taper from the top of each sole bar, so that they will stand up square off the floor. Press an acetal bearing into the hole in the back of each axlebox. Glue the solebars to the floor/underframe, sandwiching the wheelsets between, as shown in diagram. Make sure the ends of floor and solebar are flush and that the axles are free running and have a small amount of endplay.

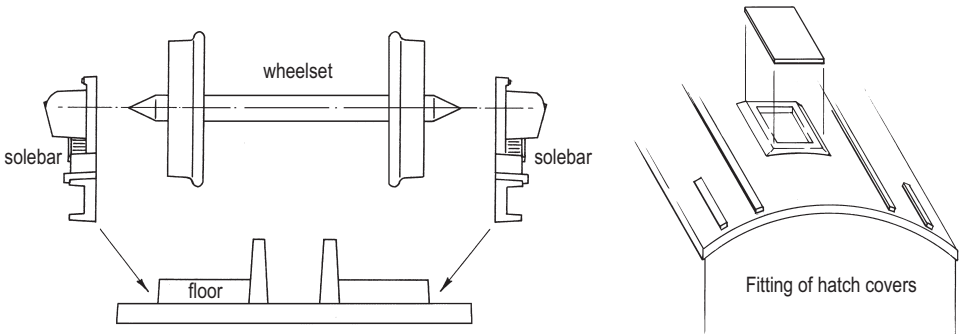

Carefully file the ends of the sides so that they are square and a good fit with the wagon end. Glue the sides to the ends to form an open box. Note that the sides fit between the ends. Ensure that the reinforcing straps on the sides and ends line up and the corners are square before putting the assembly aside to dry.

Check the fit of the roof and trim as necessary. When the roof fits properly glue it in place. Glue three hatch covers into place. Cut the square plastic rod into two 21mm lengths. Glue rods to mounting blocks on wagon ends with one end on the drain outlet and other end to the right of the coupler. See photo.

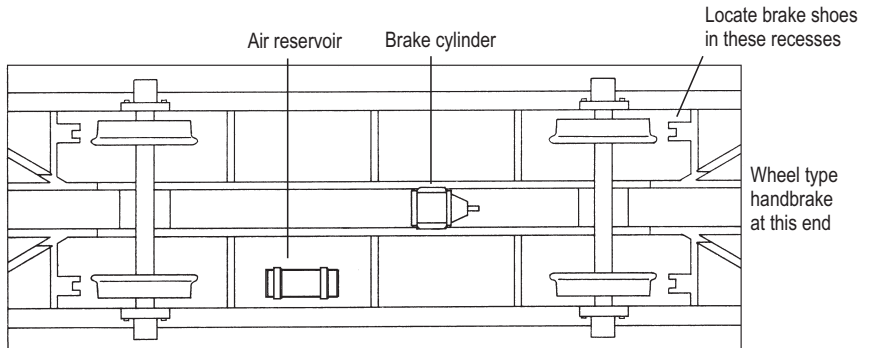

Trim the floor to a good fit in the body and then glue in place.

Glue the brake cylinder to the centre sills and the air reservoir to the floor as shown in the diagram. Glue four brake shoes into the floor recesses as shown in the diagram, ensure that the brake shoes do not interfere with the free running of the wheels. The kit is designed to use Kadee No5 or No58 couplers which will need to have the 'ears' removed from the sides of the draft box to fit.

If it is desired to super detail the wagon, etched brass shunter's steps and brake wheels are available in Steam Era Models Kit E5.

Painting and Decals

The wagon should be painted overall VR Wagon Red with white lettering and a brown roof. We recommend Steam Era Models VR Wagon Red spraying enamel for sides, ends and underframe and Humbrol Matt Dark Earth for the roof. Decals are provided for both metric and imperial load/tare and codes. Refer to the diagrams for placement of lettering.

To Apply Decals

1. Trim decals close to lettering to remove excess film.
2. Immerse in water for ten to fifteen seconds, then set aside on a tissue until decal straightens out.
3. Slide decal into position. If it is necessary to adjust the final position, use a small brush that has been dipped in water.
4. Use a tissue to soak up excess water.
5. The use of a decal setting agent such as Solvaset is recommended to assist decals in snuggling down over rivets etc.
6. A flat finish such as DDV or Estapol matt applied to the entire model will give a uniform dull finish.

NOTE: DECALS ADHERE BEST TO A GLOSS SURFACE.

